

NOTES: UNLESS OTHERWISE SPECIFIED

1. MATERIAL: NOTED.
2. FINISH: AFTER ASSMBLY.
3. ALL DIMENSIONS ARE IN INCHES UNLESS OTHERWISE SPECIFIED.
4. INSTALLATION: FOR 6 INCH CURB, INVERT OF CURB-O-LET TO BE 1/2 INCH ABOVE FLOW LINE ± 1/4 INCH, FOR 8 INCH CURBS BOTTOM OF CURB-O-LET TO BE INBEDDED IN CONCRETE ± 1/4 INCH.
5. STAMP COMPANY NAME IN 3/4" HIGH LETTERS APPROXIMATELY WHERE SHOWN .02-.04 DEEP.

REVISIONS			
REV.	DESCRIPTION	DATE	APPROVED
A	RELEASE FOR PRODUCTION		

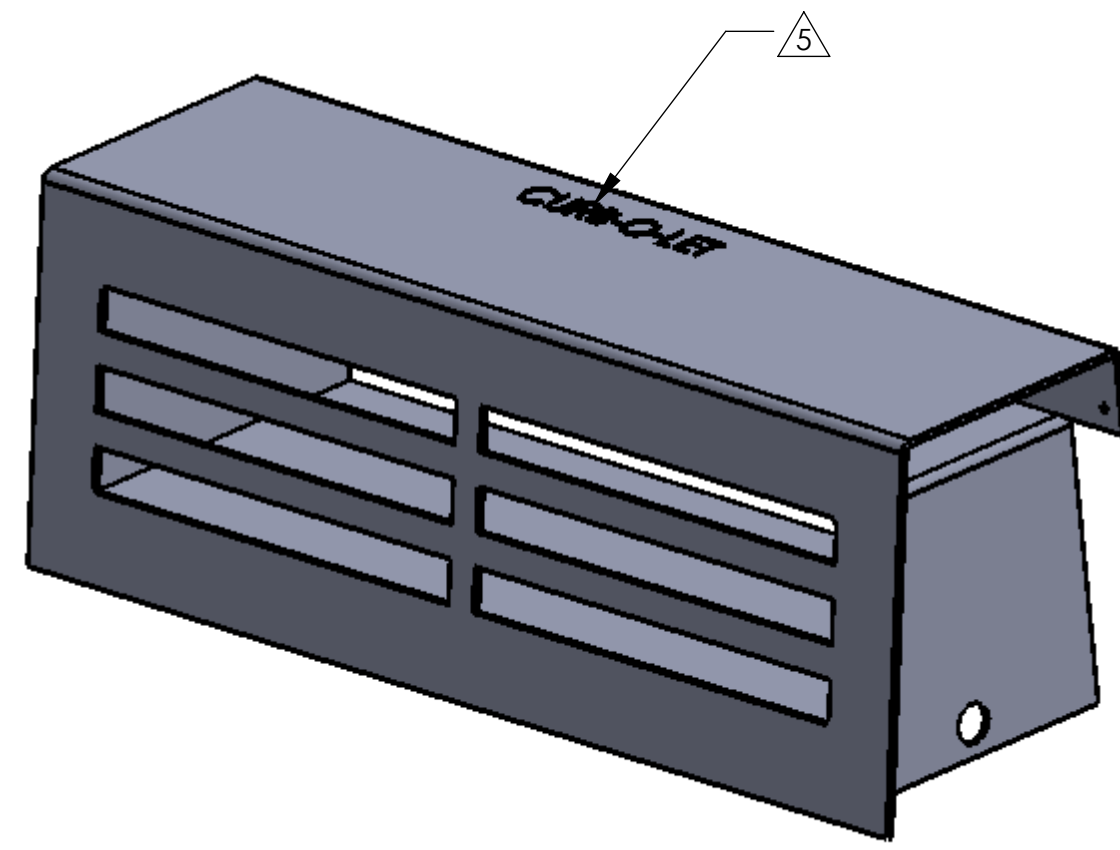
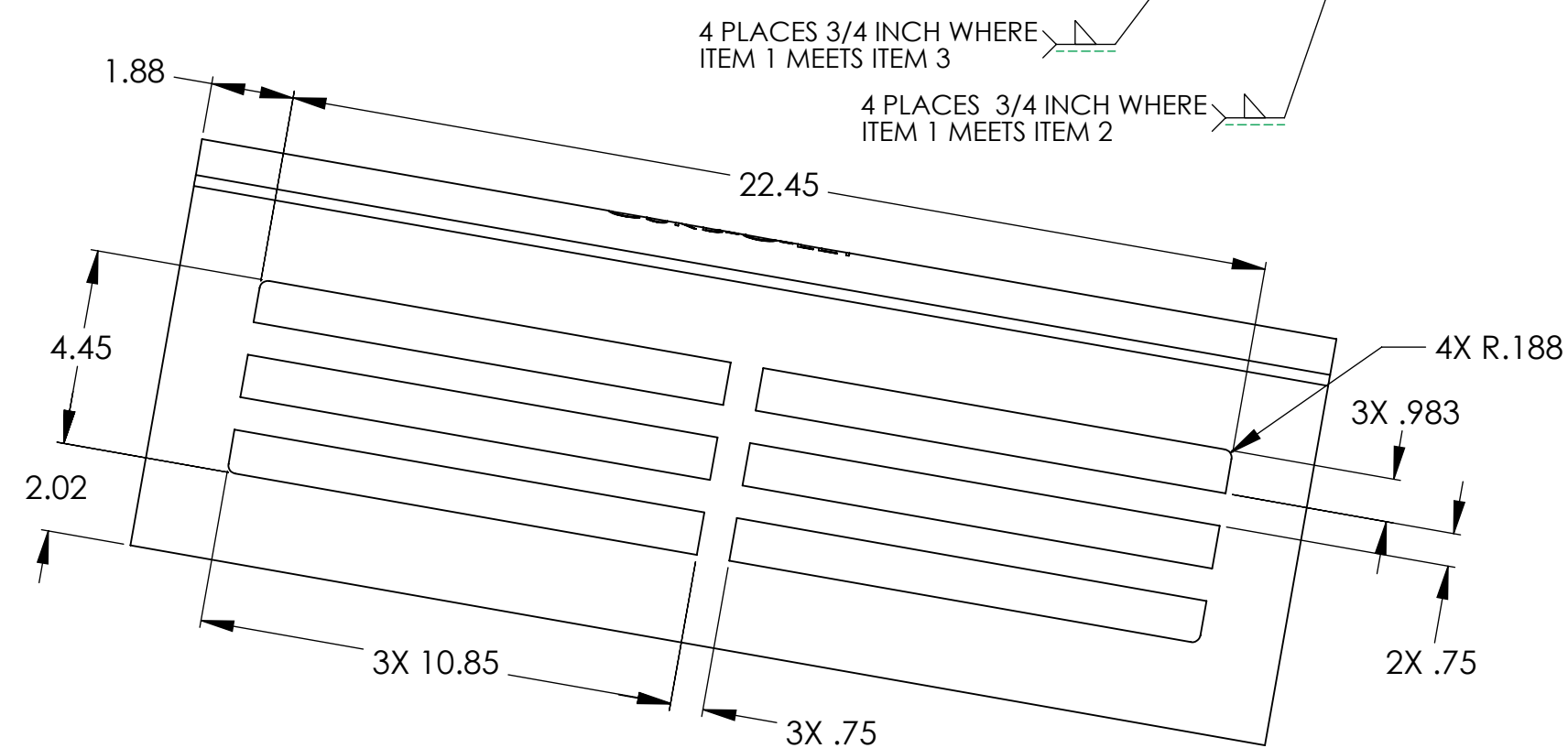
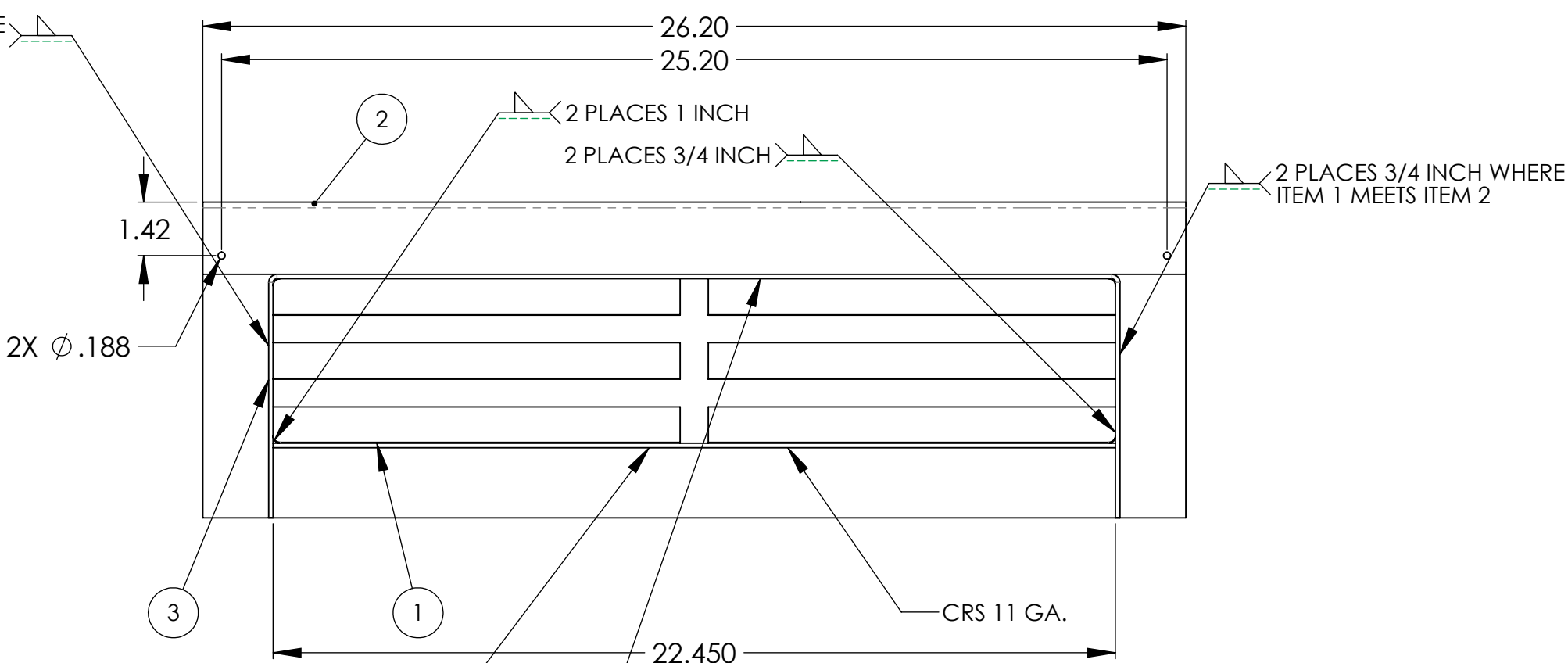
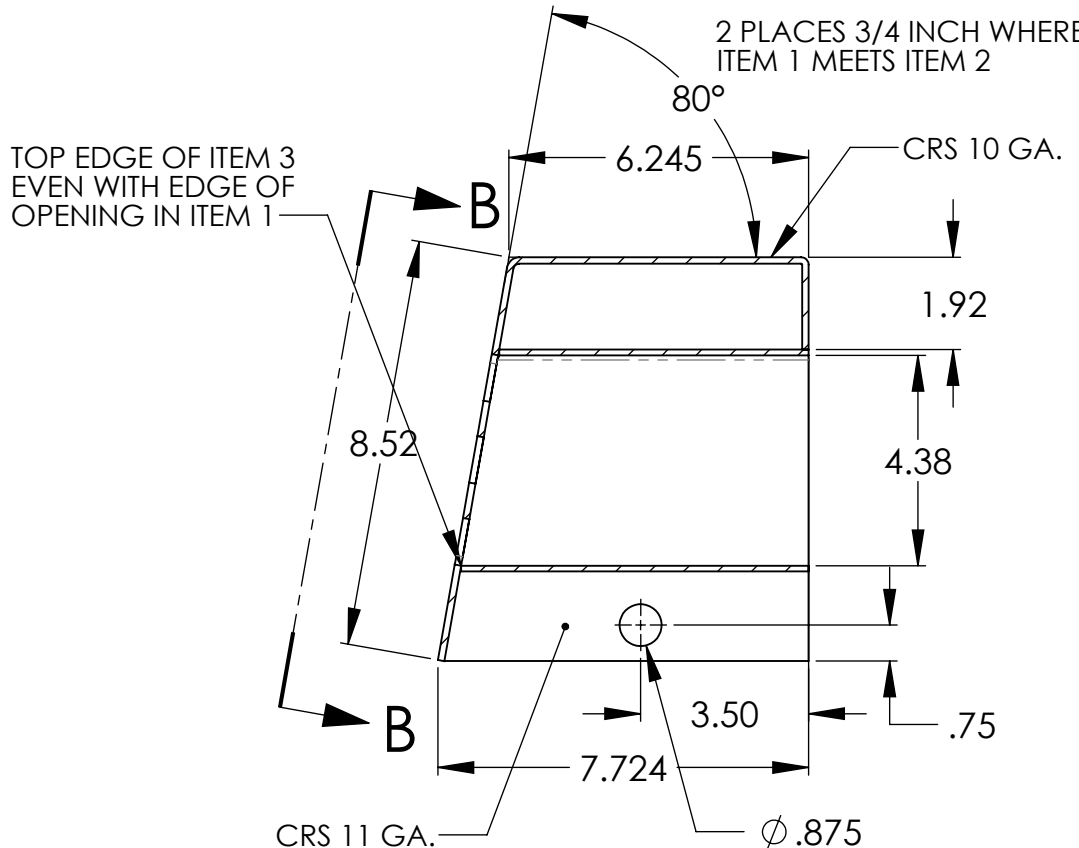
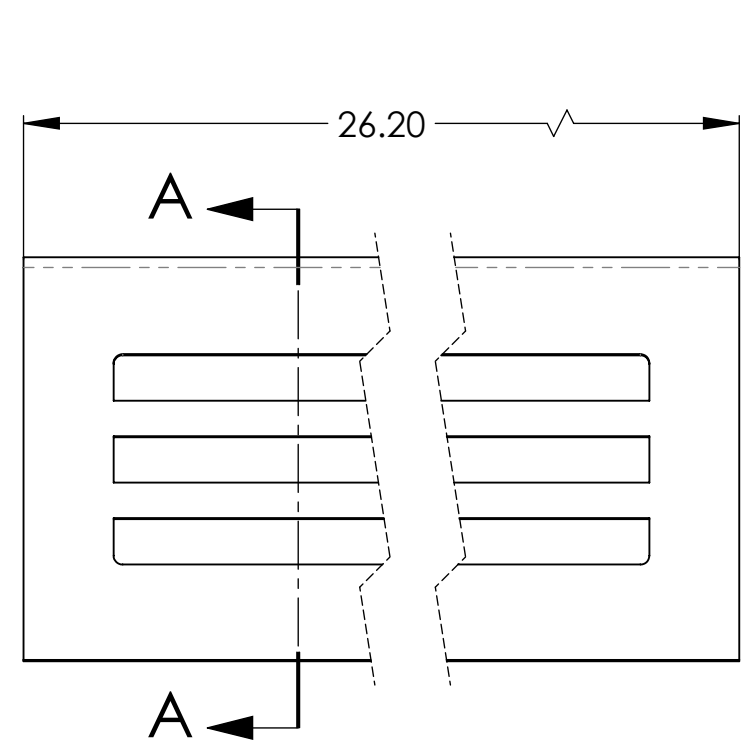

ITEM NO.	PART NUMBER	DESCRIPTION	QTY.
1	TCD422-3	PLATE	1
2	TCD422-1	COVER	1
3	TCD422-2	BRACKET	1

Supplied By:

TRENCHDRAIN SUPPLY

877-903-7246

www.trenchdrainsupply.com

PROPRIETARY AND CONFIDENTIAL
THE INFORMATION CONTAINED IN THIS DRAWING IS THE SOLE PROPERTY OF <INSERT COMPANY NAME HERE>. ANY REPRODUCTION IN PART OR AS A WHOLE WITHOUT THE WRITTEN PERMISSION OF <INSERT COMPANY NAME HERE> IS PROHIBITED.

UNLESS OTHERWISE SPECIFIED:		NAME	DATE
DIMENSIONS ARE IN INCHES	DRAWN	D.C.	10-14-16
TOLERANCES:	CHECKED		
FRACTIONAL ±	ENG APPR.		
ANGULAR: MACH ± BEND ±	MFG APPR.		
TWO PLACE DECIMAL ±	Q.A.		
THREE PLACE DECIMAL ±	COMMENTS:		
INTERPRET GEOMETRIC TOLERANCING PER:			
MATERIAL			
FINISH			
APPLICATION			
DO NOT SCALE DRAWING			

CURB-O-LET

TITLE: **TCD422 OUTLET ASSEMBLY**

SIZE: **C** DWG. NO.: **TCD422-O** REV: **A**

SCALE: 1:4 WEIGHT: SHEET 1 OF 1