

APPROVED BY THE CITY OF LOS ANGELES  
BUREAU OF ENGINEERING/PUBLIC WORKS

REVISIONS			
REV.	DESCRIPTION	DATE	APPROVED
A	RELEASE FOR PRODUCTION		
B	CLARIFIED DIMENSIONS	6-13-17	
C	ENLARGED NOTE FONT	07/07/17	
D	ADDED CITY APPROVAL	07/07/17	

NOTES: UNLESS OTHERWISE SPECIFIED

1. MATERIAL: NOTED.
2. FINISH: AFTER ASSEMBLY.
3. ALL DIMENSIONS ARE IN INCHES UNLESS OTHERWISE SPECIFIED.
4. INSTALLATION: FOR 6 INCH CURB, INVERT OF CURB-O-LET TO BE 1/2 INCH ABOVE FLOW LINE ± 1/4 INCH, FOR 8 INCH CURBS BOTTOM OF CURB-O-LET TO BE INBEDDED IN CONCRETE ± 1/4 INCH.
5. STAMP COMPANY NAME IN 3/4" HIGH LETTERS APPROXIMATELY WHERE SHOWN .02-.04 DEEP.

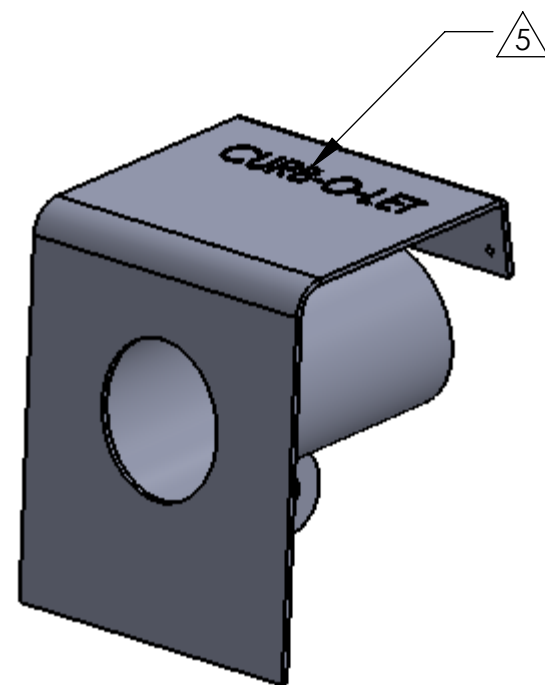
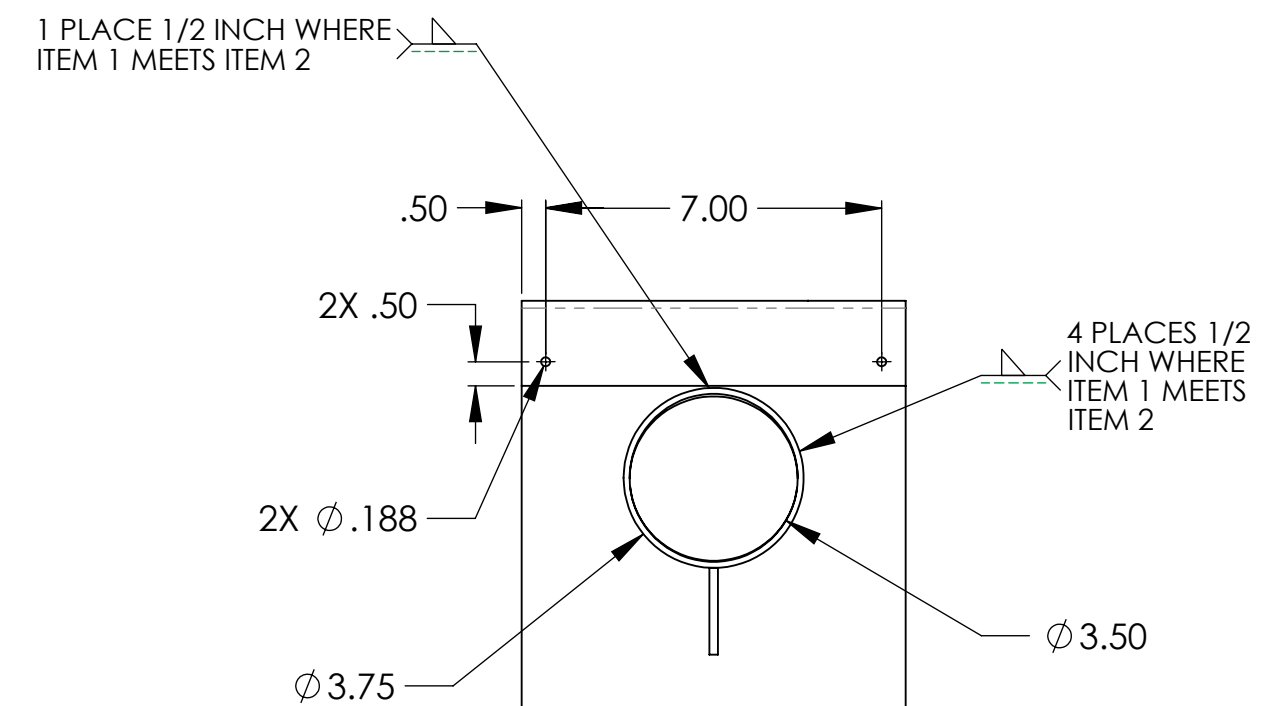
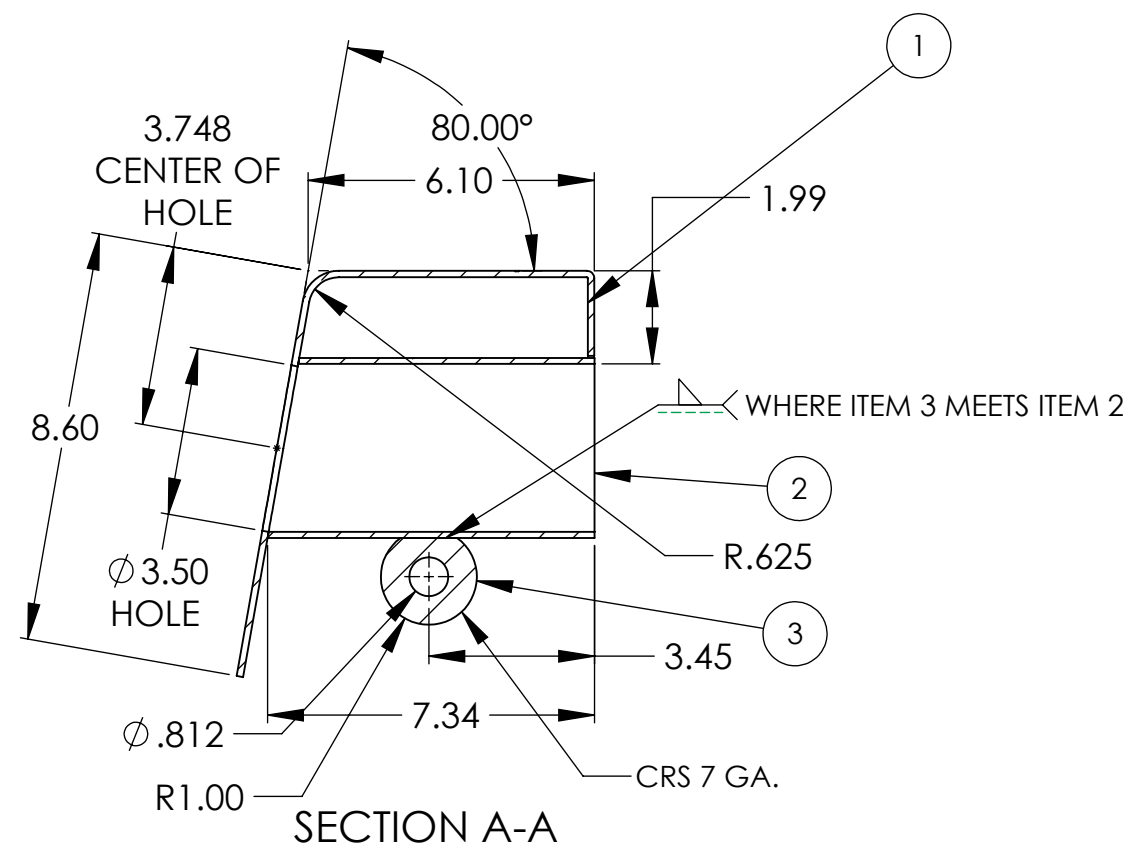
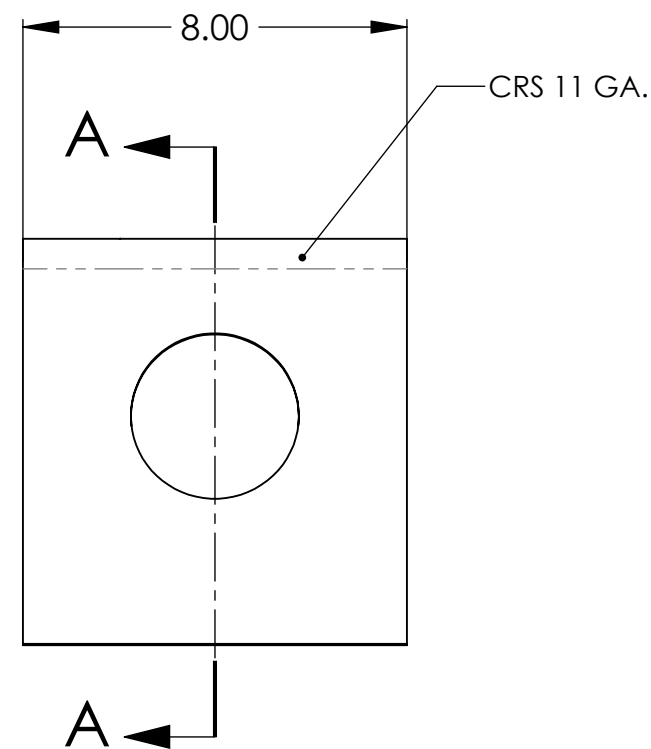

ITEM NO.	PART NUMBER	DESCRIPTION	QTY.
1	TCD3RD-1NS	TOP	1
2	TCD3RD-2NS	TUBE	1
3	TCD3RD-3NS	WASHER	1

UNLESS OTHERWISE SPECIFIED:		NAME	DATE	<b>CURB-O-LET</b> TITLE: <b>TCD3RD-NS ASSEMBLY</b> SIZE DWG. NO. REV <b>C TCD3RD-NS D</b> SCALE: 1:4 WEIGHT: SHEET 1 OF 1
DIMENSIONS ARE IN INCHES		DRAWN	D.C.	
TOLERANCES:		CHECKED		
FRACTIONAL ±		ENG APPR.		
ANGULAR: MACH ± BEND ±		MFG APPR.		
TWO PLACE DECIMAL ±		Q.A.		
THREE PLACE DECIMAL ±		COMMENTS:		
INTERPRET GEOMETRIC TOLERANCING PER:				
MATERIAL				
FINISH				
NEXT ASSY	USED ON			
APPLICATION				
DO NOT SCALE DRAWING				

PROPRIETARY AND CONFIDENTIAL  
THE INFORMATION CONTAINED IN THIS DRAWING IS THE SOLE PROPERTY OF <INSERT COMPANY NAME HERE>. ANY REPRODUCTION IN PART OR AS A WHOLE WITHOUT THE WRITTEN PERMISSION OF <INSERT COMPANY NAME HERE> IS PROHIBITED.

Supplied By:

**TRENCHDRAIN SUPPLY**

877-903-7246

www.trenchdrainsupply.com