

APPROVED BY THE CITY OF LOS ANGELES  
BUREAU OF ENGINEERING/PUBLIC WORKS

REVISIONS			
REV.	DESCRIPTION	DATE	APPROVED
A	RELEASE FOR PRODUCTION		
B	CLARIFIED DIMENSIONS	06/21/17	
C	ENLARGED NOTE FONT	07/07-17	
D	ADDED CITY APPROVAL	07/07/17	

NOTES: UNLESS OTHERWISE SPECIFIED

1. MATERIAL: NOTED.
2. FINISH: AFTER ASSEMBLY.
3. ALL DIMENSIONS ARE IN INCHES UNLESS OTHERWISE SPECIFIED.
4. INSTALLATION: FOR 6 INCH CURB, INVERT OF CURB-O-LET TO BE 1/2 INCH ABOVE FLOW LINE  $\pm$  1/4 INCH, FOR 8 INCH CURBS BOTTOM OF CURB-O-LET TO BE INBEDDED IN CONCRETE  $\pm$  1/4 INCH.
5. STAMP COMPANY NAME IN 1/2" HIGH LETTERS APPROXIMATELY WHERE SHOWN .02-.04 DEEP.

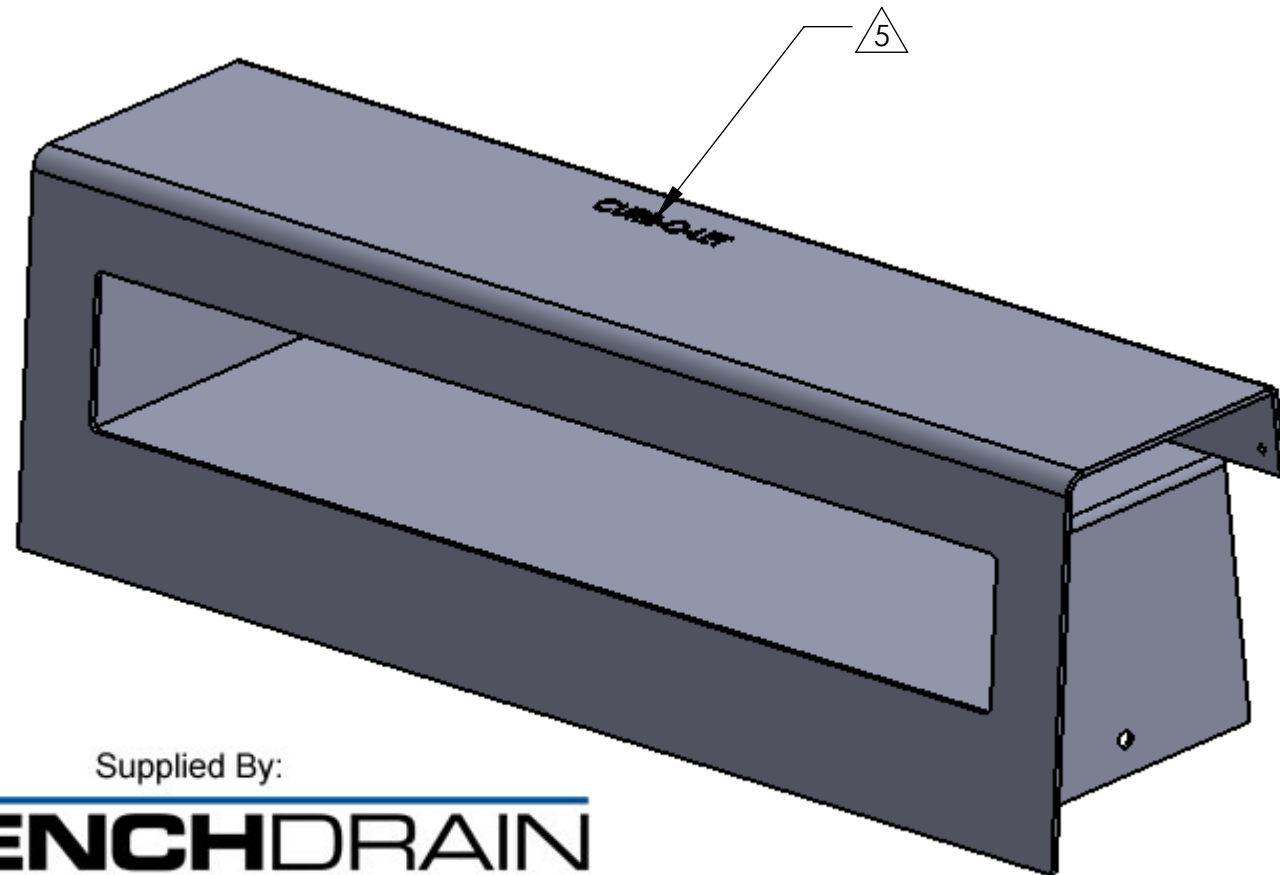
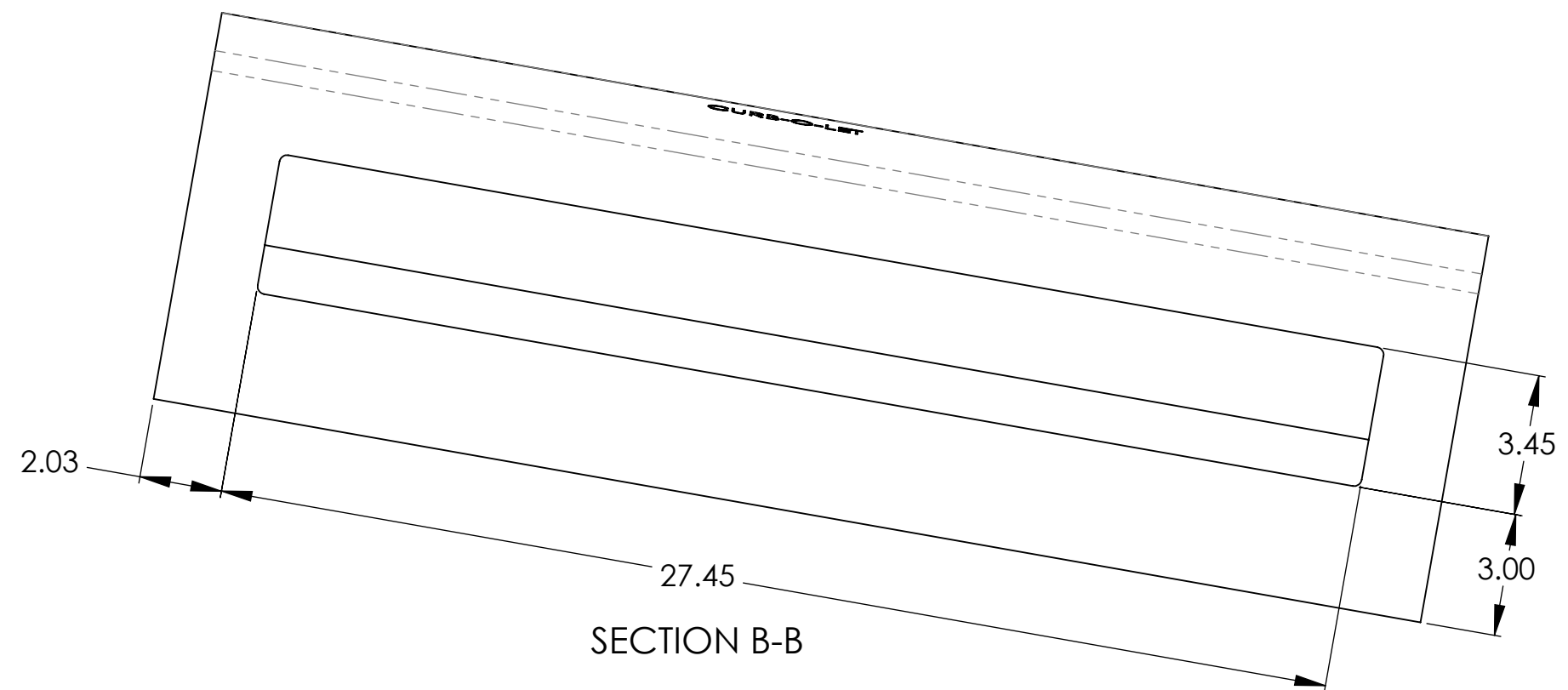
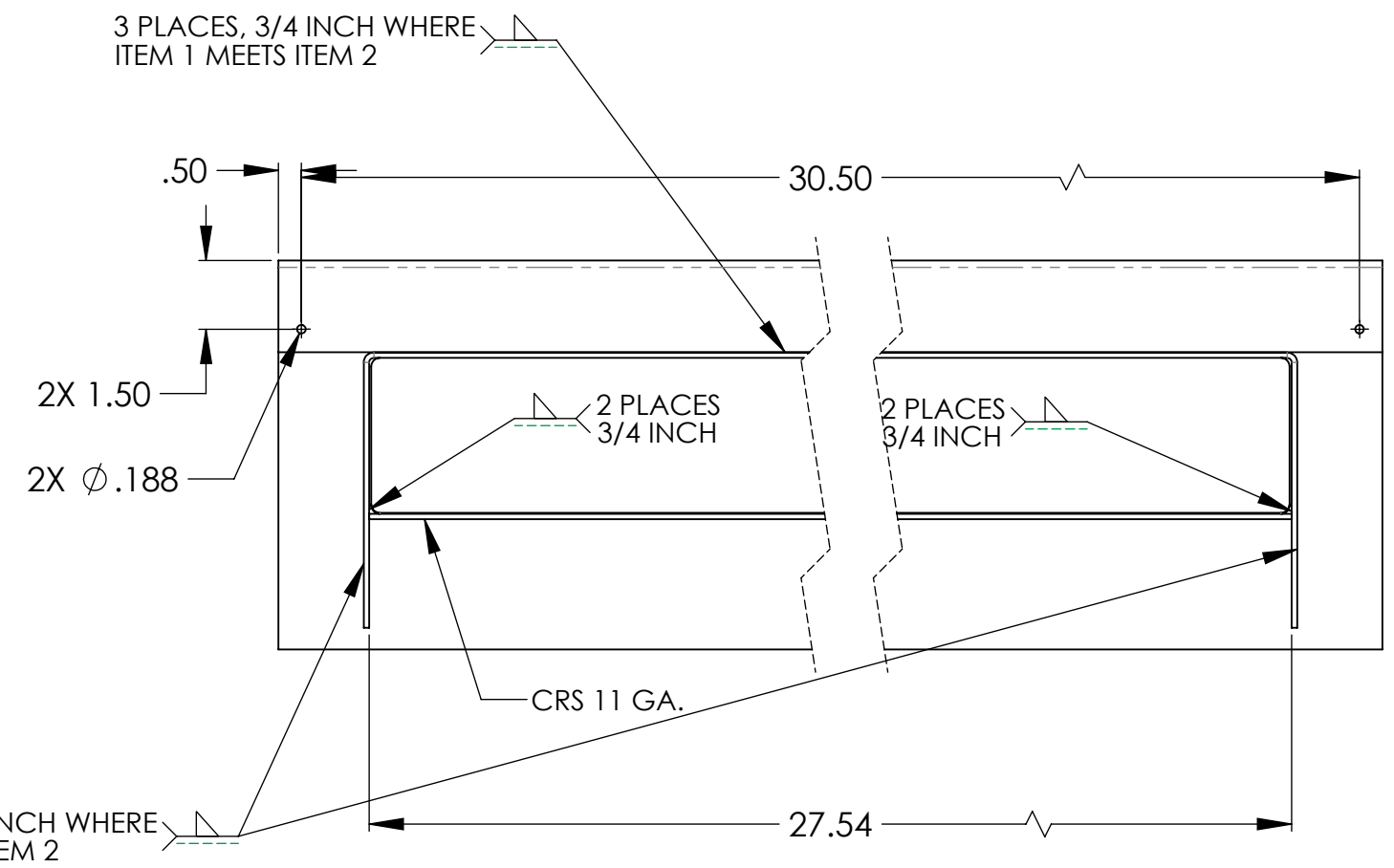
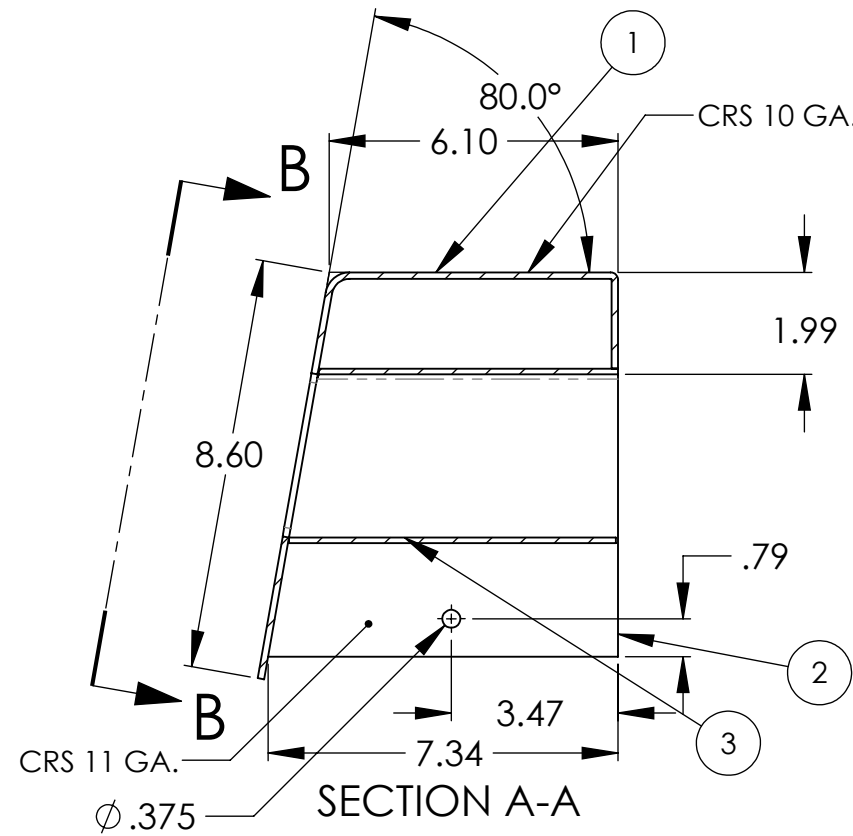
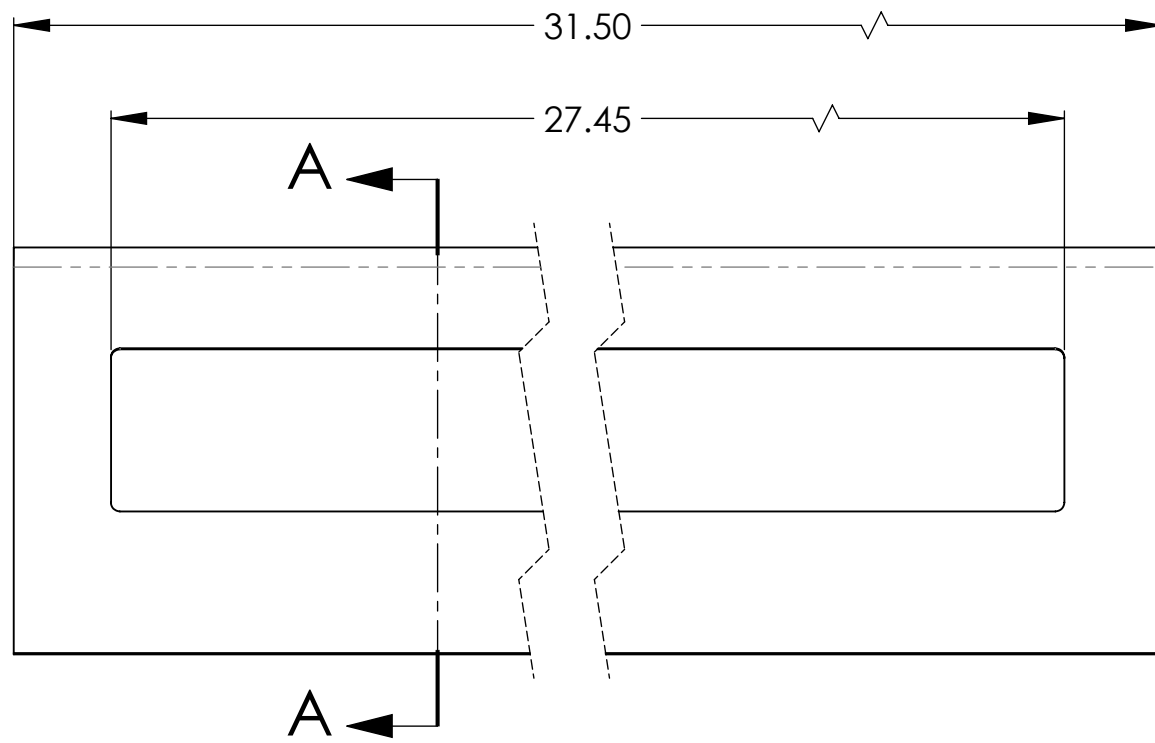

ITEM NO.	PART NUMBER	DESCRIPTION	QTY.
1	TCD327-1NS	COVER	1
2	TCD327-2NS	BRACKET	1
3	TCD327-3NS	PLATE	1

UNLESS OTHERWISE SPECIFIED:		NAME	DATE
DIMENSIONS ARE IN INCHES	DRAWN	D.C.	11/08/16
TOLERANCES:	CHECKED		
FRACTIONAL $\pm$	ENG APPR.		
ANGULAR: MACH $\pm$ BEND $\pm$	MFG APPR.		
TWO PLACE DECIMAL $\pm$	Q.A.		
THREE PLACE DECIMAL $\pm$	COMMENTS:		
INTERPRET GEOMETRIC TOLERANCING PER:			
MATERIAL			
FINISH			
APPLICATION			
DO NOT SCALE DRAWING			

PROPRIETARY AND CONFIDENTIAL  
THE INFORMATION CONTAINED IN THIS  
DRAWING IS THE SOLE PROPERTY OF  
<INSERT COMPANY NAME HERE>. ANY  
REPRODUCTION IN PART OR AS A WHOLE  
WITHOUT THE WRITTEN PERMISSION OF  
<INSERT COMPANY NAME HERE> IS  
PROHIBITED.

TITLE: TCD327-NS ASSEMBLY		
SIZE C	DWG. NO. TCD327-NS	REV D
SCALE: 1:4	WEIGHT:	SHEET 1 OF 1

Supplied By:  
**TRENCH DRAIN  
SUPPLY**  
877-903-7246  
www.trenchdrainsupply.com